

# Infratek DC27 CONTROLLED DC- AND AC-LOADS

## Battery Load Units / Load Banks / 50-400Hz Single- and 3-phase Loads



The **Infratek DC27 Loads** offer the user versatility, flexibility, lightweight, and sturdy design, combined with precise measurement technique to obtain complete battery information, or UPS- and generator characteristic. Three load types are available: **LD260** and **LD60** are DC- as well as AC-Loads for up to 600V, 1200A, 100kW; **LD100** is a DC-Load for 1V / 100A up to 100V/8A.

### Versatile Battery Load Unit

Battery Load Units measure capacity of back-up batteries by means of a discharge test. Premature capacity decrease, weak blocks, or weak cells are detected. Periodic tests assure crucial equipment to run in case of power failure.

Infratek DC27 Battery Load Units LD260 and LD60 discharge batteries in the voltage range 10V to 600V at currents from 1A up to 1200A. The DC27 consists of a control module and a programmable high current load. Its versatility is almost unlimited; it performs tasks such as battery discharge without detaching battery, precise measurements of battery parameters and cell voltages versus discharge, charge estimation which makes a total discharge unnecessary, on the spot battery analysis, battery data storing for later analysis on a PC, and finally the DC27 control module analyzes battery systems under float charge, determines discharging – charging efficiency, and performs step current tests on DC power supplies.

The DC27 control module drives one master load and up to 31 slave loads. The programmable loads are factory set for 10V-60V/150A -, or 10V to 260V/70A operation. The weight of a load is only 8.5kg. To discharge high voltage batteries,

loads can be series connected. High current discharge results by parallel connecting slave loads.

Load LD100 can discharge single cells, low voltage batteries, fuel cells, or DC-power supplies up to 100A. It operates in the voltage range 1V to 100V, 800W maximum. Loads can be connected in parallel but not in series. Analog input and analog output is provided for transient testing or load profile testing.

### Versatile 50Hz / 60Hz Load

One master load and one slave load can be connected to form a 50Hz, 60Hz single phase resistive load for 230V/113A – or 400V/65A operation. The load current is set in the SETUP menu of the control module. The load characteristic is constant current, constant power, or constant resistance.

Three phase loads, star – or delta connected, can be configured using one master load and five slave loads. Maximum power for a basic 3-phase load is 78kW. By parallel connecting slave loads, power can be increased to a maximum of 390kW.

## Features At A Glance

### Control Module

- Five Main Functions: F1: Battery Discharge, F2: Float Charge Optimizer, F3: Charge Optimizer, F4: Step Current Testing, F5: 1- and 3-phase AC Load Testing.
- Controls one Master Load and up to 31 Slave Loads
- Discharge current 1A-1200A
- Switches loads off when final voltage reached
- Discharge: constant current / power /resistance
  
- Discharge testing without disconnecting battery
- Predicts charge content
- Measures cell voltages (max. 100 cells)
  
- Simple to operate with 11 soft keys
- Blue display monitor 58 x 108mm, displays all values
- 0.5 % accuracy
- Acoustic signaling of events
- Displays guidance for correct operation
- Displays warnings and takes proper action
- Light weight control module, 1.2kg
  
- Saves battery data for later analysis and printing
- Performs on the spot battery analysis
  
- Windows Battery Analysis Software available

### Master Load / Slave Load, LD260, LD60

- Factory set for 0-60V / 150A-, or 0-260V / 70A operation
- Covers wide voltage range 10-600V, series connection
- Covers wide current range 1-1200A, parallel connection
- Up to 4 loads in series, up to 8 loads in parallel
  
- LD260: 190-260V, 70A/13kW max. AC- and DC-Load
- LD60: 40-60V, 150A max. AC- and DC-Load
- Light weight: 8.5kg; universal 90V-240V supply
- Reverse polarity protection
- Rise time = 50 $\mu$ s
- Slave Loads: can be series- or parallel connected to Master Load

### Master Load / Slave Load, LD100

- Factory set for 0-100V / 100A / 800W operation
- Up to 8 loads in parallel
- Single cell discharge at 100A per load
- Light weight: 6.5kg, universal 90V-240 supply
- Reverse polarity protection
- Rise time 20 $\mu$ s
- Analog input for transient testing
- Analog output for transient current

## Easy To Use

The DC27 load bank in its minimal configuration consists of the control module and a master load. To start a discharge test you simply connect the control cables to the load, energize the load, set in the SETUP menu of the control module the desired discharge current, number of cells, and final cell voltage. Also, select the discharge function F1. Connect the master load to the battery, connect the voltage measuring cable from the control module to the battery poles, and press the START key. The monitor displays discharge current, voltage at the battery poles, charge, energy, time, cell voltage, and in a reserved text field presents status, warnings, or errors.

The current will rise to its preset value and will be kept constant until the final voltage is reached. At that time the control module stops the measurement, issues an alarm and holds all battery data for storage in nonvolatile memory.

If you need to discharge a 48V Telecom battery at 300A, for example, you connect one slave load in parallel to the master load.

The procedures to use the functions F2 through F5 is similar to the one described above.

The control module is operated using 6 menu soft keys M1 through M6 and five cursor soft keys. The user is menu guided, all operations are self-explanatory. In addition, the display monitor with backlight can easily be read in dark rooms.

## High Performance

With only three different load types the user can discharge batteries in the whole voltage range up to 600V. Series connected loads can discharge high voltage batteries. Very large currents are obtained by parallel connection. The control module commands all load types and does the controlling based on the programmed criteria constant current,- power,- resistance. It performs precision measurements of discharge current, (no current clamps are needed) battery voltage, charge, energy, elapsed time, and cell- or block voltages. Battery data are accumulated and can be saved in nonvolatile memory. During discharge you have the option to read cell – or block voltages into the control module memory. Values of up to 100 cells can be entered.

A unique feature of the control module gives you a conservative estimation of charge after approximately 20 % of total discharge time. With reasonable certainty you can use this estimate as a guide to either terminate or continue discharge. This saves you time, energy, and eventually money.

If you discharge to the final voltage you can display the battery discharge characteristic.

Using the 260V loads single- and three phase AC generating systems (UPS, generators) can be tested. Star- and delta connected loads up to 390kW can be formed. All loads are steered by just one single control module.

Depending on the type of Control module, you can make use of up to 5 different functions F1, F2, F3, F4, and F5. F1: Battery Discharge, F2: Float Charge Optimizer, F3: Charge Optimizer, F4: Step current testing on large DC power supplies, and F5: Load Testing of single- and three phase AC-supplies.

## Specifications

<b>Control Module</b>		controls all loads, acquires and displays battery- or UPS data	
<b>Main Functions</b>	Selectable by soft keys F1: Battery discharge; F2: Float Charge Optimizer; F3: Charge Optimizer; F4: Step load testing on large DC power supplies; F5: Load Testing on AC-supplies / UPS:	Up to 5 functions in a Control Module.	
<b>Current</b>	Ranges: 12A, 40A, 120A, 400A, 1200A (max 1600A)	Auto-ranging	
	Accuracy: $\pm(0.2\% \text{ of reading} + 0.3\% \text{ of range})$ ; 23°C $\pm$ 3°C	30% to 140% of range	
<b>Voltage, Cell Voltage</b>	Ranges: 1V, 3V, 10V, 30V, 100V, 300V, 1000V, max 600V	Auto-ranging	
	Accuracy: $\pm(0.2\% \text{ of reading} + 0.3\% \text{ of range})$ ; 23°C $\pm$ 3°C	30% to 140% of range	
<b>Charge</b>	Ranges: mAh, Ah, kAh, MAh; 5 digits	Auto-ranging	
	Accuracy: $\pm 0.5\%$ of reading; 23°C $\pm$ 3°C	Charge / Discharge	
<b>Energy</b>	Ranges: mWh, Wh, kWh, MWh; 5 digits	Auto-ranging	
	Accuracy: Add accuracy %-figures of current and voltage	Charge / Discharge	
<b>Time</b>	Accuracy: $\pm 0.1\%$ ; display in decimal notation	e.g. 3.5002h	
<b>Estimated Charge</b>	Accuracy: $\pm 5\%$ typical	Lead Acid Batteries	
<b>Display</b>	Blue LC-graphic display with EL backlight, temp. compensated. Displays 6 values (5 digits and decimal point) incl. units. 40 % of display is reserved for help and status information. Plots are drawn on full size display.	58 x 108mm; 128 x 240 pixels	
<b>Load Control</b>	Discharge: constant current, - power, or - resistance	Set in SETUP menu	
	Current setting: 1A-1600A / 1W-13kW / 0.01-1000 $\Omega$	Set in SETUP menu	
	Current stabilization: LD260, $\pm 0.002A/V$ LD60, $\pm 0.02A/V$ LD100, $\pm 0.2A$	$\pm 1A$ at 50V / Load $\pm 0.46A$ at 230V / Load	
	Control cable to load: 15 pole + 4 pole	DB 15, max. 10m	
	Number of loads: Max. 8 loads in parallel, 4 loads in series.	Loads of same rating	
<b>Options</b>	<ul style="list-style-type: none"> <li>RS-232 incl. Infratek Windows Battery Analysis Software.</li> <li>Cell voltage measurement</li> <li>Clamp input 0-200A. Is used when battery during discharge remains connected to equipment it serves.</li> </ul>	Windows 2000, 98, 95, NT, ME, XP	
<b>Dimensions Weight / Case Dielectric Strength Temperature</b>	75 x 160 x 245mm 1.2kg / light gray plastic case voltage input to case; current path to case 0-35°C operating, -10 -50°C storage	2kV; 2kV	
<b>LD260</b> Master Load, Slave Load; Application: Utility-UPS testing up to 600V; 1- and 3-phase AC-testing			
<b>Max. Values</b>	260V, 13kW, 70A; max. 3 in series at 600V total	Max. 8 in parallel	
<b>Characteristic</b>	190-260V: max current = 13kW/voltage; <190V: max current in A = 0.375 x (voltage - 3V)	Rise time = 50 $\mu$ s	
<b>Discharge Examples</b>	600-540V: 3 series loads, const. current 0-66A 540-480V: 3 series loads, const. current 0-59A 440-367V: 2 series loads, const. current 0-59A 390-324V: 2 series loads, const. current 0-59A 258-216V: 2 parallel loads, const. current 0-100A 116-97V: 2 parallel loads, const. current 0-70A	max. 13kW per load max. 11kW per load max. 13kW per load max. 11.5kW per load max. 13kW per load max. 4kW per load	
<b>Protection Mains Supply Weight, Dimensions Dielectric Strength Temperature</b>	Control unit shuts off loads when maximum is exceeded. 90-240V / 50Hz, 60Hz / 30VA; IEC socket with switch 8.5kg, Carrying Strip; H x W x D = 600 x 300 x 250mm Load section to mains ground 0-35°C operating	Light gray finish 2kV	
<b>LD60</b> Master Load, Slave Load; Application: Telecom-Traction-Utility, DC-supply testing			
<b>Max. Values</b>	60V, 9kW, 150A; max 4 in series	Max. 8 in parallel	
<b>Characteristic</b>	40-60V: max curr. = 150A; <40V: max curr. in A = 4x (voltage -3V)	Rise time = 50 $\mu$ s	

	<b>Discharge Examples</b> 54 cells, 1.8V / cell 30 cells, 1.8V / cell 24 cells, 1.8V / cell 24 cells, 1.8V / cell 12 cells, 1.8V / cell	116–97V: 2 series loads, const. current 0-150A 64–54V: 1 load, const. current 0-150A 52-43V: 1 load, const. current 0-150A 52-43V: 4 parallel loads, const. current 0-600A 26-21V: 4 parallel loads, const. current 0-288A	max 8.7kW per load max 9.6kW max 7.8kW max 7.8kW per load max 1.9kW per load
	<b>Protection</b> <b>Mains Supply</b> <b>Weight, Dimensions</b> <b>Dielectric Strength</b> <b>Temperature</b>	Control unit shuts off loads when maximum is exceeded 90-240V / 50Hz, 60Hz / 30VA; IEC socket with switch 8.5kg, carrying strip; H x W x D = 600 x 300 x 250mm Load section to mains ground 0-35°C operating	Light gray finish 2kV
<b>LD100</b> Master Load, Slave Load; Application: Single cell-, Telecom-, DC-supply-testing			
	<b>Max Values</b>	100V, 100A at 1V, 800W per load	Max 8 in parallel
	<b>Characteristic</b>	Max. current = 800W/voltage; maximum 100A	Rise time = 20µs
	24 cells, 1.8V / cell 6 cells, 1.8V / cell	52V-43V: 1 Load, const. current 0-19A 13.2V-10.8V: 3 Loads, const. Current 0-227A	limited by 800W/52V limited by 2.4kW/13.2V
	<b>Protection</b> <b>Mains Supply</b> <b>Weight, Dimensions</b> <b>Dielectric Strength</b> <b>Temperature</b>	Shuts off when current, voltage, or power exceeded. 90-240V / 50Hz, 60Hz / 30VA; IEC socket with switch 6.5kg, Carrying Strip; H x W x D = 430 x 300 x 250mm Load section to mains ground 0-35°C operating	100V, 100A, 800W  Light gray finish 1kV
	<b>Analog Input</b> <b>Analog Output</b>	0-5V / 10kΩ; sensitivity = 1A/50mV 0-2.5V / 10kΩ; sensitivity = 25mV/A	Max. 10kHz square wave Current wave form

Examples of series and parallel connected DC27 Loads. One Master Load is combined with one or several Slave Loads.

- A. Two DC27 Loads of the same type (LD100, LD60, LD260) are connected in parallel. Twice the current of a single Load can be drawn from the battery. The currents drawn by the loads are joined in the current junction box.
- B. For high voltages, loads of the same type can be series connected (LD60, LD260). Example shows two loads in series; Load at top is series connected to load at bottom. Maximum battery voltage allowed is twice the maximum voltage of one load. The two series combinations are connected in parallel. The currents of the two series combinations are summed in the current junction box.
- C. Two LD260 (1 Master, 1 Slave) form one AC-Load for UPS testing. Maximum values are 260V/26kW/50, 60Hz.

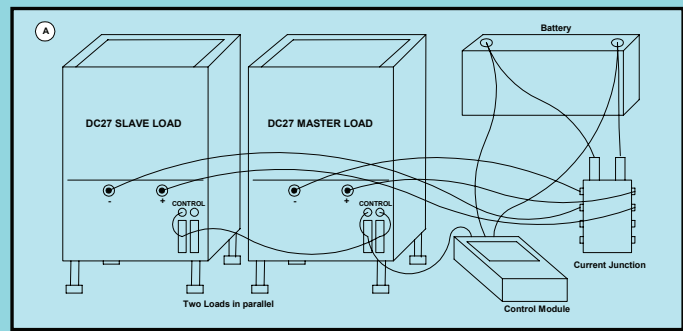
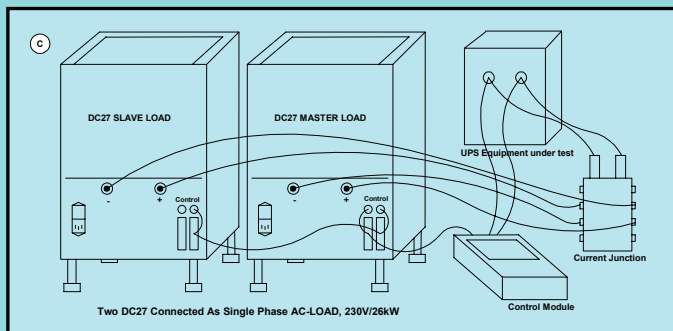
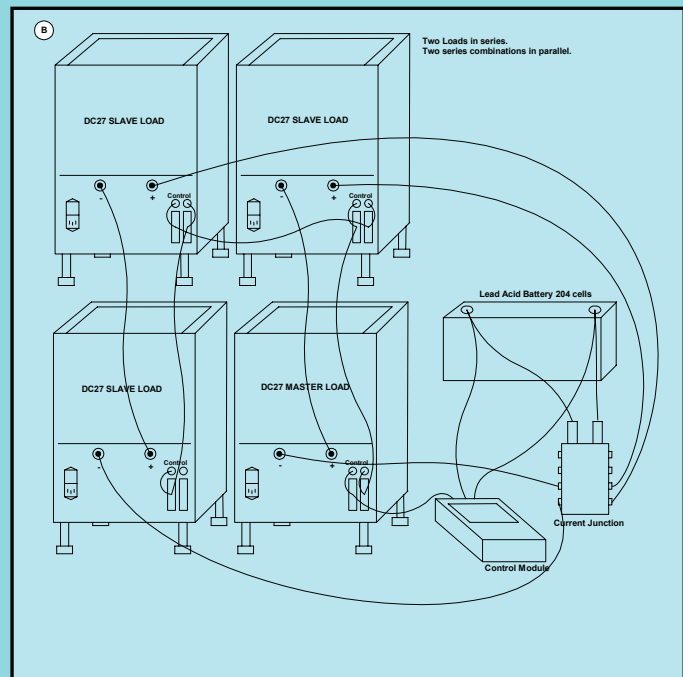

## INFRATEK AG

Weingartenstrasse 6  
8707 Uetikon am See / Switzerland  
Web: [www.infratek-ag.com](http://www.infratek-ag.com)  
phone: ++41(0)44 920 50 05

Email: [info@infratek-ag.com](mailto:info@infratek-ag.com)  
fax: ++41(0)44 920 60 34

## Distributed by: